

TITAN

WYE STRAINER • THREADED ENDS

ANSI Class 250 • Cast Bronze (ASTM B62)

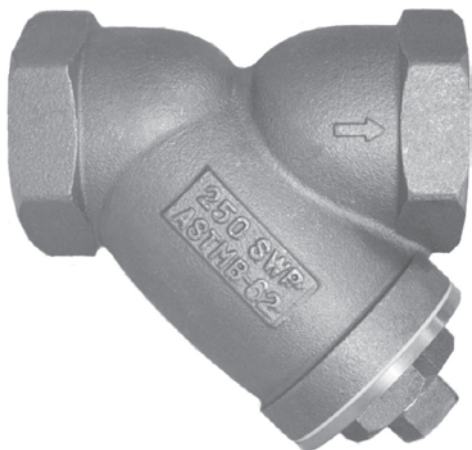

2" YS 52-BZ

Model: YS 52-BZ
Cast Bronze • ANSI Class 250
Size Range: 1/4" thru 3"

WORKING PRESSURES & TEMPERATURE - NON-SHOCK

ANSI 250 Class	Model: YS 52-BZ
WOG (Water, Oil, Gas)	400 PSI @ 150 °F
Saturated Steam	250 PSI @ 406 °F
MAX Liquid	250 PSI @ 400 °F

Features:

- STRAINER IS SELF CLEANING WHEN FITTED WITH A BLOW-DOWN VALVE
- EASILY REMOVABLE GASKETED SCREEN CAPS
- CAP GASKET IS ENCAPSULATED WITHIN A MACHINED RECESSED SEAT
- STRAIGHT THREADS ON CAP PERMIT EASY REMOVAL WHEN THE SCREEN MUST BE CLEANED. CAP ALSO HELPS TO ASSURE PROPER ALIGNMENT OF THE SCREEN WHEN REASSEMBLED
- PRECISION MACHINED SCREEN SEAT (ENABLES FINE FILTRATIONS)
- TAPPED NPT BLOW-OFF
- DRAIN/BLOW-OFF CONNECTION FURNISHED WITH PLUG AS STANDARD
- STRAINER IS DESIGNED WITH LARGE OPEN AREA
MINIMUM 2.5 TIMES LARGER THAN CORRESPONDING PIPE SIZE
LARGE OPEN AREA ENSURES LOW PRESSURE LOSS
- HEX ENDS FOR EASY INSTALLATION

Rugged Design Ideal for HVAC, Commercial and Industrial Type Applications



TITAN FLOW CONTROL
LUMBERTON, NC USA

WYE STRAINER
MODEL: YS 52-BZ
CAST BRONZE • THREADED ENDS

ANSI
Class 250

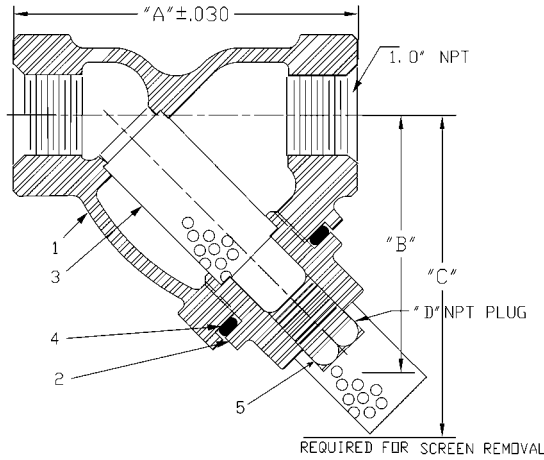

BILL OF MATERIALS		
No.	PART	MATERIALS
1	BODY	CAST BRONZE ASTM B62
2	CAP	CAST BRONZE ASTM B62
3	SCREEN*	STAINLESS STEEL
4	GASKET*	TEFLON
5	PLUG	CAST BRONZE ASTM B62

*Recommended spare parts

Notes:

- Designed in accordance with ASME B16.15
- Cap gasket is encapsulated in machined recessed seat

DIMENSIONS:

SIZE	in	1/4	3/8	1/2	3/4	1	1 1/4	1 1/2	2	2 1/2	3
	mm	8	10	15	20	25	32	40	50	65	80
A DIMENSION FACE TO FACE	in	2.25	2.25	2.75	3.00	3.75	4.43	4.93	5.68	8.31	9.25
	mm	57.15	57.15	69.85	76.20	95.25	112.52	125.22	144.27	211.07	234.95
B DIMENSION CTR. LINE TO BOTTOM	in	2.59	2.59	2.71	3.03	3.65	4.60	4.96	5.87	7.60	8.46
	mm	65.78	65.78	68.83	76.96	92.71	116.84	125.98	149.09	193.04	214.88
C DIMENSION SCREEN REMOVAL	in	3.00	3.75	4.00	4.25	4.75	6.00	7.00	8.00	12.00	12.00
	mm	76.20	95.25	101.60	107.95	120.65	152.40	177.80	203.20	304.80	304.80
D DIMENSION NPT BLOW-OFF	in	1/8	1/8	1/4	1/4	3/8	1/2	1/2	1	1 1/4	1 1/4
	mm	6	6	8	8	10	15	15	25	32	32
ASSEMBLED WEIGHT	lb	0.88	0.88	0.88	1.32	1.76	3.52	4.84	7.04	14.52	17.16
	kg	0.40	0.40	0.40	0.60	0.80	1.60	2.20	3.20	6.60	7.80
Flow Coefficient	C _v	0.7	2	8	15	22	38	42	70	110	160

Dimensions, weights, and flow coefficients are for reference only. When required, always request certified drawings.

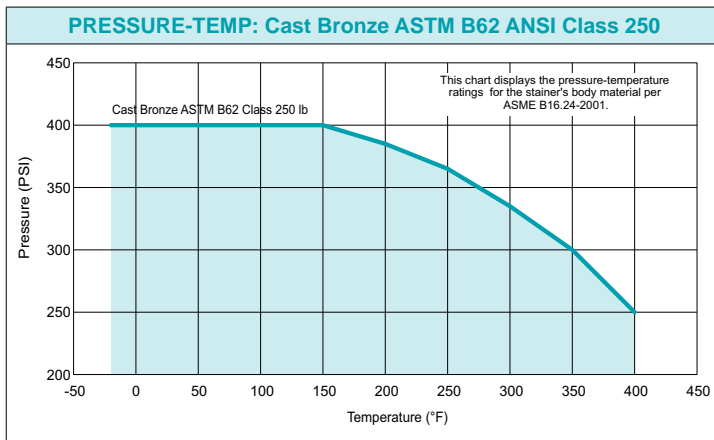

WORKING PRESSURES & TEMPERATURE - NON-SHOCK	
ANSI Class 250	YS 52-BZ
WOG (Water, Oil, Gas)	400 PSI @ 150 °F
Saturated Steam	250 PSI @ 406 °F
Max Liquid	250 PSI @ 400 °F

STANDARD SCREEN SELECTIONS				
Sizes	Water Service	Open Area	Steam	Open Area
1/4" ~ 2"	20 mesh	51.8%	30 mesh	44.8%
2 1/2" ~ 3"	1/16 (.0625)	41%	3/64 (.045)	36%

A wide range of optional wire mesh and perforated screens are available.

REFERENCED STANDARDS	
Cast Bronze Threaded Fittings	ANSI B16.15
Cast Copper Alloy Pipe Flanges and Fittings	ANSI B16.24

TESTING:

Strainers are individually, hydrostatically tested at 1.5 x the 100 °F rating, rounded off to the next higher 25 PSI measurement .

Ordering Code: _____ Size: _____
 Customer/Project: _____
 Inq./P.O. No.: _____
 Titan Order No.: _____
 Certified By: _____ Date: _____

Engineering Specification Submittal

Titan FCI makes every effort to ensure the information presented on our literature accurately reflects exact product specifications. However, as changes occur, there may short-term differences between actual product specifications and the data on our literature. Titan FCI reserves the right to make specification changes to improve our products without prior notification.

WYE STRAINER • YS 52-BZ

Size	Model Number	Description	Drawing No.