

TITAN

WYE STRAINER • FLANGED ENDS

ANSI 250 lb • CAST IRON



6" YS 59-CI

Model: YS 59-CI

Size Range: 2" thru 12"

(Sizes 14" ~ 24" Available - Consult Factory)

WORKING PRESSURES & TEMPERATURE - NON-SHOCK

ANSI 250 lb Class	YS 59-CI: 2" ~ 12"	YS 59-CI: 14" ~ 24"
WOG (Water, Oil, Gas)	500 PSI @ 150 °F	300 PSI @ 150 °F
Saturated Steam	250 PSI @ 406 °F	200 PSI @ 387 °F
MAX Liquid	250 PSI @ 450 °F	200 PSI @ 406 °F

Features:

- SELF CLEANING TYPE
- BOLTED COVER FLANGE ALLOWS EASY REMOVAL OF SCREEN FOR CLEANING
ALSO HELPS TO ENSURE PROPER ALIGNMENT OF SCREEN DURING REASSEMBLY
- PRECISION MACHINED SEAT ENSURES PROPER SEATING OF SCREEN
- TAPPED NPT BLOW-OFF
- DRAIN CONNECTION FURNISHED WITH PLUG AS STANDARD
- STRAINER HAS LARGE OPEN AREA
MINIMUM 2.5 TIMES LARGER THAN CORRESPONDING PIPE SIZE
- EPOXY PAINTED EXTERIOR IS STANDARD
- INLET AND OUTLET BOSSES ARE PROVIDED FOR GAUGE TAPPING
- OPTIONAL COVER DESIGNS (I.E. HINGE TYPE)
- BODY MEETS APPLICABLE ASTM STANDARDS
- RAISED FACED FLANGES

Economical Design, Ideal For HVAC, Commercial and Industrial Applications



TITAN FLOW CONTROL

290 Corporate Drive
Lumberton, NC 28358
Tel: 910-735-0000 Fax: 910-735-3848
titan@titanfci.com www.titanfci.com

WYE STRAINER
MODEL: YS 59-CI
ANSI 250 LB • FLANGED ENDS
HEAVY DUTY - CAST IRON BODY

ANSI Class 250 lb

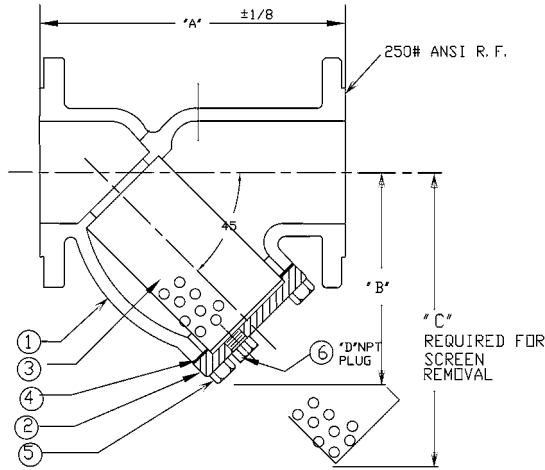

BILL OF MATERIALS		
No.	PART	MATERIAL
1	Body	Cast Iron ASTM A126 Gr. B
2	Cover	Cast Iron ASTM A126 Gr. B
3	Screen*	Type 304 Stainless Steel
4	Gasket*	Non-Asbestos Garlock Gasket
5	Cap Screw	Carbon Steel
6	Plug	Carbon Steel

*Recommended spare parts

Notes:

- Epoxy Painted Exterior is Standard
- Designed in accordance with ANSI B16.1

DIMENSIONS:

SIZE	in	2"	2 1/2"	3"	4"	5"	6"	8"	10"	12"
	mm	50	65	80	100	125	150	200	250	300
A DIMENSION FACE TO FACE	in	8.62	10.62	12.00	14.50	16.62	19.18	23.37	27.37	32.00
	mm	219	270	305	369	423	488	594	696	813
B DIMENSION CTR. LINE TO BOTTOM	in	6.00	7.37	8.37	10.00	11.37	13.37	16.12	19.00	22.00
	mm	153	188	213	254	289	340	410	483	559
C DIMENSION SCREEN REMOVAL	in	9.00	11.00	12.50	15.00	17.00	20.00	24.12	28.50	33.00
	mm	229	280	318	381	432	508	613	724	839
D DIMENSION NPT BLOW-OFF	in	1/2	1	1	1 1/2	2	2	2	2	2
	mm	15	25	25	40	50	50	50	50	50
ASSEMBLED WEIGHT	lb	25.5	42.5	54.5	94.0	150.0	206.0	336.0	508.0	750.0
	kg	11.6	19.3	24.7	42.6	68.0	93.3	152.2	230.2	339.8
Flow Coefficient	C _v	70	120	160	260	400	570	950	1600	2200

Dimensions and weights are for reference only. When required, request certified drawings.

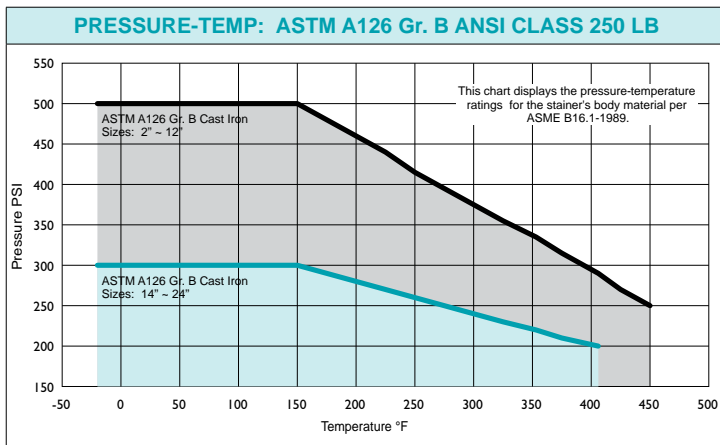

WORKING PRESSURES & TEMPERATURE - NON-SHOCK		
ANSI 250 lb Class	YS 59-CI: 2" - 12"	YS 59-CI: 14" - 24"
WOG (Water, Oil, Gas)	500 PSI @ 150 °F	300 PSI @ 150 °F
Saturated Steam	250 PSI @ 406 °F	200 PSI @ 387 °F
Max Liquid	250 PSI @ 450 °F	200 PSI @ 406 °F

STANDARD SCREEN SELECTIONS				
Sizes	Water Service	Open Area	Steam	Open Area
1/2" - 4"	1/16 (.0625)	41%	3/64 (.045)	36%
5" - 10"	1/8 (.125)	40%	3/64 (.045)	36%
12"	1/8 (.125)	40%	1/16 (.0625)	41%

A wide range of optional wire mesh and perforated screens are available.

REFERENCED STANDARDS	
Design	B16.1
Shell Wall Thickness	B16.1
Pressure vs. Temp. Rating	B16.1

TESTING:

Strainers are individually, hydrostatically tested at 1.5 x the 100 °F rating, rounded off to the next higher 25 PSI measurement .

Ordering Code: _____ Size: _____
 Customer/Project: _____
 Inq./P.O. No.: _____
 Titan Order No.: _____
 Certified By: _____ Date: _____

Engineering Specification Submittal

Titan FCI makes every effort to ensure the information presented on our literature accurately reflects exact product specifications. However, as changes occur, there may short-term differences between actual product specifications and the data on our literature. Titan FCI reserves the right to make specification changes to improve our products without prior notification.

WYE STRAINER - CAST IRON - FLANGED ENDS • YS 59-CI

Size	Model Number	Description	Drawing No.