



TITAN FLOW CONTROL, INC.

SILENT CHECK VALVE ♦ SINGLE DISC ♦ THREADED ENDS

ANSI CLASS 300 ♦ STAINLESS STEEL BODY

MODEL: CV 80-SS

STAINLESS STEEL BODY
TEFLON (PTFE) SEAT



FEATURES

SIZE RANGE:
3/8" THROUGH 3"

- ◆ **QUICK CLOSURE TO REDUCE WATER HAMMER**
SILENT SHUT-OFF IS ACHIEVED VIA THE FULLY AUTOMATIC, SPRING ASSISTED DISC THAT CLOSES NEAR ZERO FLOW VELOCITY. THE LIGHTWEIGHT, CENTER GUIDED DISC DESIGN CREATES A POSITIVE SHUTOFF PRIOR TO FLOW REVERSAL AND HELPS TO KEEP SLAMMING AND SURGES TO A MINIMUM.
- ◆ **MINIMAL HEAD LOSS**
THE CONTOUR OF BODY PROVIDES A SHORT AND STRAIGHT FLOW PATH THAT GENERATES VERY LITTLE TURBULENCE. ADDITIONALLY, THE SPRING-LOADED, CENTER GUIDED DISC IS DESIGNED WITH VERY LOW CRACKING PRESSURE WHICH REDUCES THE AMOUNT OF ENERGY REQUIRED TO OPEN THE VALVE.
- ◆ **BUBBLE TIGHT SEAL**
BY UTILIZING A TEFLON SEAT AND GASKET IN CONJUNCTION WITH PRECISION MACHINED SEALING SURFACES, THE CV 80-SS MAINTAINS A BUBBLE TIGHT SEAL THAT MEETS OR EXCEEDS API 598 LEAKAGE REQUIREMENTS.
- ◆ **DESIGNED FOR LONG SERVICE LIFE**
THE CV 80-SS UTILIZES A HIGHLY RELIABLE INVESTMENT CASTING, STAINLESS STEEL CONSTRUCTION, AND A SIMPLIFIED DESIGN (ONLY SIX PARTS) THAT CAN PROVIDE A LONG SERVICE LIFE FOR A WIDE VARIETY OF APPLICATIONS.
- ◆ **VERSATILE AND ECONOMICAL DESIGN**
THE CV 80-SS CAN BE INSTALLED IN ANY POSITION (HORIZONTAL OR VERTICAL WITH UPWARD FLOW) - CONSULT FACTORY FOR VERTICAL WITH DOWNWARD FLOW. HEX ENDS ARE PROVIDED FOR QUICK AND EASY INSTALLATIONS

TECHNICAL

PRESSURE/TEMPERATURE RATING
SS - ASTM A351 GR. CF8M - CLASS 300

WOG: 720 PSI @ 100 °F
Max Liquid: Consult Factory
Max Steam: Not Recommended

SEAT MATERIAL
TEMPERATURE RANGE

PTFE: -100 ~ 400 °F

SPRING MATERIAL
MAXIMUM TEMPERATURE

Type 316 SS: 450 °F

APPLICATIONS

MARKETS: OIL & GAS PRODUCTION, GENERAL INDUSTRY, CHEMICAL INDUSTRY, PETROCHEMICAL INDUSTRY, POWER, FOOD & BEVERAGE INDUSTRIES.

SERVICE: CHEMICAL / STEAM / NITROGEN LINES, GAS INJECTION, CONDENSATE RECOVERY, PUMP & COMPRESSOR DISCHARGE, PUMP JACK FLOW LINES, CHILLER & BOILER FEED

PTFE: RECOMMENDED FOR MOST CHEMICAL ENVIRONMENTS INCLUDING ACIDS, BASE, OILS, STEAM AND OTHER PROCESS FLUIDS. OFFERS EXCELLENT TEAR, ABRASIVE, CHEMICAL, ACID, AND ALKALI RESISTANCE. NOT RECOMMENDED FOR HIGH PRESSURE STEAM OR LARGE TEMPERATURE VARIATION APPLICATIONS

The above data represents common market and service applications. No representation or guarantee, expressed or implied, is given due to the numerous variations of concentrations, temperatures and flow conditions that may occur during actual service.

TITAN FLOW CONTROL, INC.
YOUR PIPELINE TO THE FUTURE!

Tel: 910-735-0000 ♦ Fax: 910-738-3848 ♦ titan@titanfci.com ♦ www.titanfci.com
290 Corporate Drive ♦ PO Box 7408 ♦ Lumberton, NC 28358



TITAN FLOW CONTROL, Inc.
 290 Corporate Drive E-mail: titan@titanfci.com
 Lumberton, NC 28358 Web: www.titanfci.com
 Tel: 910.735.0000
 Fax: 910.738.3848

IN-LINE • SILENT CHECK VALVE
CENTER GUIDED • THREADED ENDS
MODEL: CV 80-SS

Stainless Steel Body • PTFE Seat and Gasket

ANSI Class
 300 lb

BILL OF MATERIALS ⁽¹⁾

| No. | PART | MATERIAL |
|-----|-----------------------|------------------------------------|
| 1 | CAP | ASTM A351 Gr. CF8M Stainless Steel |
| 2 | STEM | ASTM A351 Gr. CF8M Stainless Steel |
| 3 | GASKET ⁽²⁾ | PTFE |
| 4 | SEAT | PTFE |
| 5 | SPRING | Type 316 Stainless Steel |
| 6 | BODY | ASTM A351 Gr. CF8M Stainless Steel |

- Notes:**
1. Bill of Materials represents standard materials. Equivalent materials may be substituted at the manufacturer's discretion.
 2. Denotes recommended spare parts.

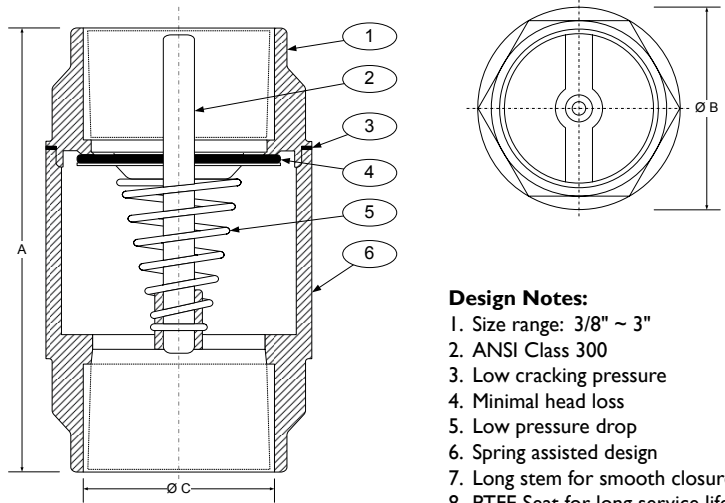

- Design Notes:**
1. Size range: 3/8" ~ 3"
 2. ANSI Class 300
 3. Low cracking pressure
 4. Minimal head loss
 5. Low pressure drop
 6. Spring assisted design
 7. Long stem for smooth closure
 8. PTFE Seat for long service life

DIMENSIONS AND PERFORMANCE DATA ⁽¹⁾

| SIZE | in | 3/8 | 1/2 | 3/4 | 1 | 1 1/4 | 1 1/2 | 2 | 2 1/2 | 3 |
|-----------------------------------------|----------------|-------|-------|-------|-------|-------|-------|-------|-------|-----|
| | mm | 10 | 15 | 20 | 25 | 32 | 40 | 50 | 65 | 80 |
| A DIMENSION FACE TO FACE | in | 2.086 | 2.204 | 2.480 | 2.913 | 3.188 | 3.582 | 3.818 | C/F | C/F |
| | mm | 53 | 56 | 63 | 74 | 81 | 91 | 97 | C/F | C/F |
| ØB DIMENSION OUTSIDE DIAMETER | in | .905 | 1.181 | 1.377 | 1.614 | 2.165 | 2.440 | 3.228 | C/F | C/F |
| | mm | 23 | 30 | 35 | 41 | 55 | 62 | 82 | C/F | C/F |
| ØC DIMENSION INSIDE DIAMETER | in | .669 | .826 | 1.023 | 1.259 | 1.614 | 1.850 | 2.322 | C/F | C/F |
| | mm | 17 | 21 | 26 | 32 | 41 | 47 | 59 | C/F | C/F |
| ASSEMBLED WEIGHT | lb | .1 | .2 | .3 | 1 | 1.5 | 2.5 | 3.5 | C/F | C/F |
| | kg | .05 | .1 | .1 | .5 | .7 | 1.1 | 1.6 | C/F | C/F |
| Flow Coefficient | C _v | 6 | 7 | 14 | 20 | 40 | 40 | 80 | C/F | C/F |
| Cracking Pressure ⁽²⁾ | psi | ≤ .5 | ≤ .5 | ≤ .5 | ≤ .5 | ≤ .5 | ≤ .5 | ≤ .5 | C/F | C/F |

1. Dimensions, weights, and flow coefficients are provided for reference only. When required, always request certified drawings.
2. The listed valve cracking pressure only applies to horizontal installations. For vertical installations, cracking pressure is higher. Please consult factory.

REFERENCED STANDARDS & CODES

| CODE | DESCRIPTION |
|-------------------|-------------------------------------------|
| ANSI B1.1 | Unified Inch Screw Threads |
| ANSI B1.20.1 | Pipe Threads - General Purpose |
| ANSI B16.34 | Valves - Flanged, Threaded & Welding Ends |
| ASTM A351 GR CF8M | Austenitic Steel Castings |

PRESSURE - TEMPERATURE RATING

Body Material - ASTM A351 GR. CF8M - CLASS 300

WOG (Water, Oil, Gas): 720 PSI @ 100 °F

Max Liquid: Consult Factory ⁽¹⁾

Max Steam: Not Recommended

SEAT AND GASKET TEMPERATURE RATING

| Seat Material | Temperature Range |
|----------------|-------------------|
| Teflon (PTFE): | -100 ~ 400 °F |

SPRING TEMPERATURE RATING

| Spring Material | Maximum Temperature |
|-----------------------|---------------------|
| T-316 Stainless Steel | 450 °F |

PRESSURE-TEMPERATURE RATINGS FOR CF8M ⁽¹⁾ CLASS 300

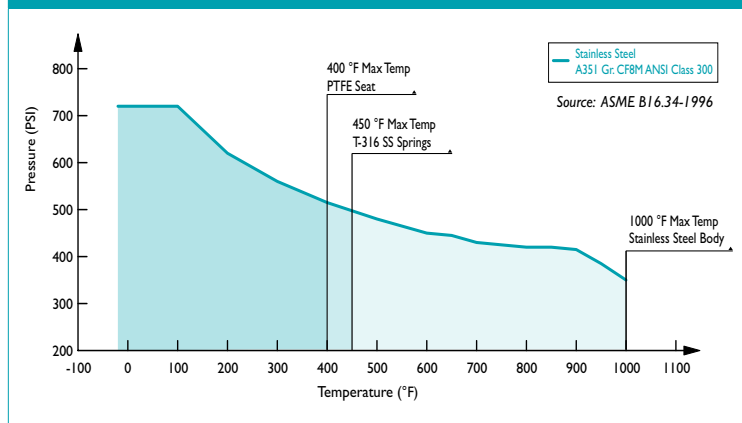

1. The above chart displays the pressure-temperature ratings for the valve's body material per ASME/ANSI B16.34-1996. For reference, maximum temperature limits have been added for seat and spring materials. PTFE seat limits the maximum temperature for this valve. Stainless Steel not recommended for prolonged use above 1000 °F

Titan FCI makes every effort to ensure the information presented on our literature accurately reflects exact product specifications. However, as product changes occur, there may be short-term differences between actual product specifications and the information contained within our literature. Titan FCI reserves the right to make design and specification changes to improve our products without prior notification. When required, request certified drawings.