



TITAN FLOW CONTROL, INC.

SWING CHECK VALVE ♦ WAFER TYPE ♦ SINGLE DISC

ANSI CLASS 150 ♦ CARBON AND STAINLESS STEEL

SIZES: 2" ~ 12"

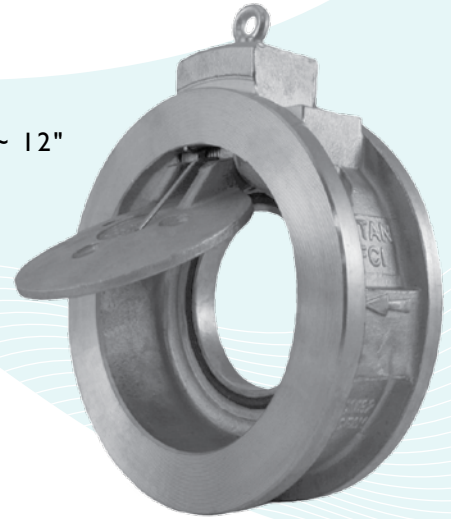

MODELS: CV 32-CS

(Carbon - Viton)

CV 32-SS

(Stainless - PTFE)

FEATURES

- ◇ **ECONOMICAL DESIGN**
LOW WEIGHT AND SHORT LAYING LENGTH PRODUCE SAVINGS IN INITIAL COST, SPACE REQUIREMENTS, AND INSTALLATION WHEN COMPARED TO FULL-BODY, SWING-TYPE CHECK VALVES.
- ◇ **MINIMAL HEAD LOSS**
HEAD LOSS IS MINIMIZED BY PROVIDING A SHORT, STRAIGHT AND VIRTUALLY UNOBSTRUCTED FLOW PATH. ADDITIONALLY, THE SPRING-LOADED DISC IS DESIGNED WITH VERY LOW CRACKING PRESSURE WHICH REDUCES THE AMOUNT OF ENERGY REQUIRED TO OPEN THE VALVE.
- ◇ **QUICK CLOSURE TO REDUCE WATER HAMMER**
SHUT-OFF IS ACHIEVED VIA THE FULLY AUTOMATIC, SPRING-ASSISTED DISC THAT CLOSES NEAR ZERO FLOW VELOCITY. THE LIGHTWEIGHT, SINGLE DISC DESIGN CREATES A POSITIVE SHUTOFF PRIOR TO FLOW REVERSAL WHICH HELPS TO KEEP SURGES TO A MINIMUM.
- ◇ **DURABLE, HIGH QUALITY DESIGN**
THE CV32 CHECK VALVE IS AVAILABLE IN EITHER CARBON STEEL OR STAINLESS STEEL BODY CONFIGURATIONS, WHICH ALLOW IT TO PERFORM WELL IN HIGHER TEMPERATURE APPLICATIONS. THE CARBON STEEL UNITS ARE EPOXY PAINTED. ADDITIONALLY, BOTH MODELS FEATURE ANTI-CORROSIVE, STAINLESS STEEL TRIM (DISC, SPRING, SHAFT) AS STANDARD.
- ◇ **RESILIENT SOFT SEATS**
RESILIENT SOFT SEATS (VITON AND PTFE O-RING) COUPLED WITH PRECISION MACHINED SEALING SURFACES HELP TO ENSURE A BUBBLE TIGHT SEAL THAT MEETS OR EXCEEDS API 598 TEST REQUIREMENTS.

TECHNICAL

PRESSURE/TEMPERATURE RATING
CS - ASTM A216 Gr. WCB - CLASS 150

WOG: 285 PSI @ 100 °F

PRESSURE/TEMPERATURE RATING
SS - ASTM A351 Gr. CF8M - CLASS 150

WOG: 275 PSI @ 100 °F

SEAT MATERIAL (O-RING)
TEMPERATURE RANGE

VITON: -40 ~ 400 °F
PTFE: -100 ~ 400 °F

SPRING MATERIAL
MAXIMUM TEMPERATURE

Series 300 Stainless Steel: 450 °F

APPLICATIONS

MARKETS: GENERAL INDUSTRY, CHEMICAL, PETROCHEMICAL, POWER, AND FOOD & BEVERAGE

SERVICE: INTENDED FOR LIQUID SERVICE THAT IS STEADY, CLEAN (NO ABRASIVES OR SOLIDS) AND NON-PULSATING. FLOW RATE SHOULD NOT EXCEED 15 FT/SEC. NOT RECOMMENDED FOR STEAM OR RECIPROCATING COMPRESSOR SERVICE.

PTFE PROPERTIES: RECOMMENDED FOR MOST CHEMICAL ENVIRONMENTS INCLUDING ACIDS, BASES, OILS, STEAM AND OTHER PROCESS FLUIDS. OFFERS EXCELLENT TEAR, ABRASIVE, CHEMICAL, ACID, AND ALKALI RESISTANCE. NOT RECOMMENDED FOR HIGH PRESSURE STEAM OR LARGE TEMPERATURE VARIATION APPLICATIONS.

VITON PROPERTIES: OFFERS A BROAD RANGE OF CHEMICAL RESISTANCE AND EXCELLENT HEAT RESISTANCE. GOOD MECHANICAL PROPERTIES AND COMPRESSION SET RESISTANCE. OFTEN USED IN APPLICATIONS WHERE NOTHING ELSE WILL WORK. FAIR LOW TEMPERATURE RESISTANCE AND LIMITED HOT-WATER RESISTANCE AND SHRINKAGE.

The above data represents common market and service applications. No representation or guarantee, expressed or implied, is given due to the numerous variations of concentrations, temperatures and flow conditions that may occur during actual service.

TITAN FLOW CONTROL, INC.

YOUR PIPELINE TO THE FUTURE!

Tel: 910-735-0000 ♦ Fax: 910-738-3848 ♦ titan@titanfci.com ♦ www.titanfci.com
290 Corporate Drive ♦ PO Box 7408 ♦ Lumberton, NC 28358



TITAN FLOW CONTROL, Inc.
 290 Corporate Drive E-mail: titan@titanfci.com
 Lumberton, NC 28358 Web: www.titanfci.com
 Tel: 910.735.0000
 Fax: 910.738.3848

**SWING CHECK VALVE • WAFER TYPE
 SINGLE DISC**

**MODELS: CV 32-CS (Carbon - Viton Seat)
 CV 32-SS (Stainless - PTFE Seat)**

**ANSI
 Class 150**

BILL OF MATERIALS ⁽¹⁾

No.	PART	CV 32-CS	CV 32-SS
1	Body	Carbon Steel A216 Gr.WCB	Stainless Steel A351 Gr. CF8M
2	Seat ⁽²⁾	Viton O-Ring	PTFE Commercial O-Ring
3	Disc ⁽²⁾	Stainless Steel AISI 316	Stainless Steel AISI 316
4	Plug	Carbon Steel ASTM A307B	Stainless Steel AISI 316
5	Spring ⁽²⁾	Series 300 Stainless Steel	Series 300 Stainless Steel
6	Spacer	PTFE Commercial	PTFE Commercial
7	Shaft	Stainless Steel AISI 316	Stainless Steel AISI 316
8	Eye Bolt	Carbon Steel ASTM A307B	Carbon Steel ASTM A307B

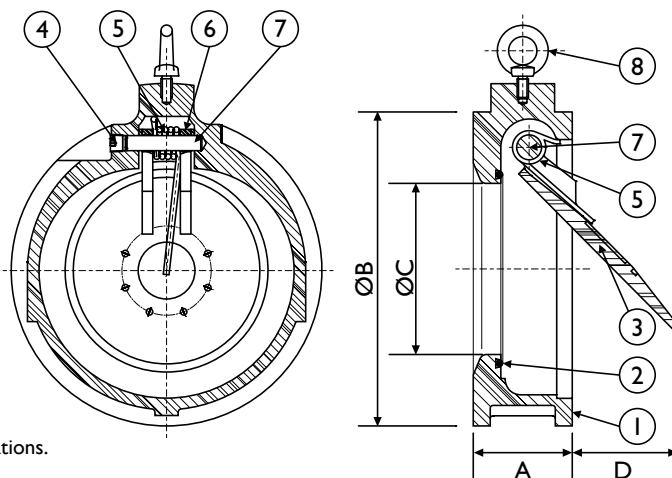

1. Bill of Materials represents standard materials. Equivalent or better materials may be substituted at the manufacturer's discretion. All materials conform to ASTM specifications.
2. Denotes recommended spare parts.

DIMENSIONS AND PERFORMANCE DATA ⁽¹⁾

SIZE	in	2	2 1/2	3	4	5	6	8	10	12
	mm	50	65	80	100	125	150	200	250	300
A DIMENSION FACE TO FACE	in	1.75	1.875	2.00	2.25	2.50	2.75	2.875	3.125	3.375
	mm	45	48	51	58	64	70	74	80	86
ØB DIMENSION OVERALL DIAMETER	in	4.125	4.875	5.375	6.875	7.75	8.75	11.00	13.375	16.125
	mm	105	124	137	175	197	223	280	340	410
ØC DIMENSION INLET DIAMETER	in	1.313	1.85	2.063	3.00	3.75	4.75	6.438	7.625	9.50
	mm	34	47	53	77	96	121	164	194	242
D DIMENSION DISC MAX TRAVEL	in	.50	.75	1.31	2.31	2.75	3.38	4.00	4.75	5.00
	mm	13	20	34	59	70	86	102	121	127
ASSEMBLED WEIGHT	lb	5.0	6.0	8.0	12.0	18.0	22.0	35.0	57.0	85.0
	kg	2.3	2.7	3.6	5.4	8.2	10.0	15.9	25.8	38.5
Flow Coefficient ⁽¹⁾	C _v	62	109	166	318	471	720	1384	2298	4153
Cracking Pressure ⁽²⁾	psi	≤ .25	≤ .25	≤ .25	≤ .25	≤ .25	≤ .25	≤ .25	≤ .25	≤ .25

1. Dimensions, weights, and flow coefficients are for reference only. When required, request certified drawings.
2. Cracking pressure is for horizontal installations only. For vertical installations, please consult factory.

PRESSURE-TEMPERATURE RATINGS

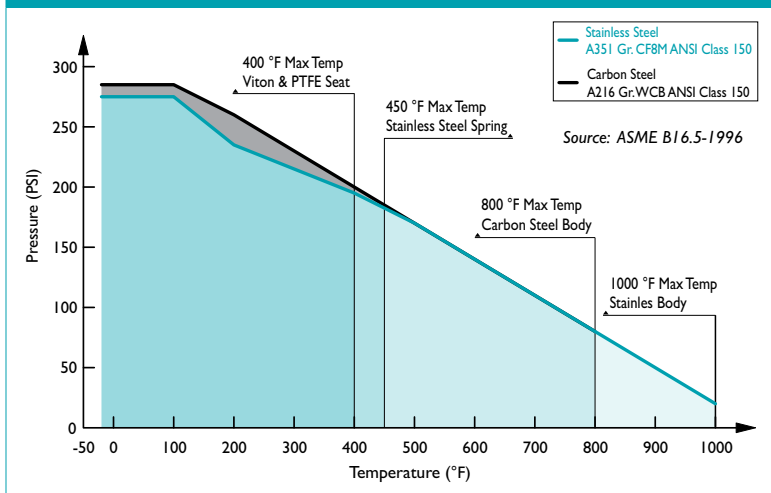

1. The above chart displays the pressure-temperature ratings for the valve's body material per ASME B1.6.5-1996. Max temperature limits have been added for seat and spring materials.

PRESSURE/TEMPERATURE RATING ⁽¹⁾

Class 150	Carbon Steel A216 Gr.WCB	Stainless Steel A351 Gr. CF8M
WOG (water, oil, gas)	285 PSI @ 100 °F	275 PSI @ 100 °F

REFERENCED STANDARDS & CODES

CODE	DESCRIPTION
ANSI B1.6.34	Steel Valves - Flanged, Threaded, & Welding Ends
ANSI B16.10	Face-to-Face & End-to-End Dimensions of Valves
ANSI B16.5	Pipe Flanges & Flanged Fittings
API 594	Wafer, Wafer-Lug, & Double Flanged Type Check Valves
API 598	Valve Inspection and Testing
MSS SP-6	Standard Finishes for Connecting-end Flanges
MSS SP-25	Standard Marking System for Valves
MSS SP-55	Quality Standard for Valve Castings

SEAT AND SPRING TEMPERATURE RATINGS ⁽¹⁾

SEAT (O-Ring)	Temperature Range
Viton	-40 ~ 400 °F
PTFE	-100 ~ 400 °F
SPRING ⁽²⁾	Maximum Temperature
Series 300 Stainless Steel	450 °F

1. The listed pressure and temperature ratings for the valve's body, seat, and spring are theoretical and may vary during actual operating conditions.
2. As the temperature increases, the load capacity of the spring diminishes significantly. At higher temperatures, a different material spring may be required. Please consult for specific application assistance.

Titan FCI makes every effort to ensure the information presented on our literature accurately reflects exact product specifications. However, as product changes occur, there may be short-term differences between actual product specifications and the information contained within our literature. Titan FCI reserves the right to make design and specification changes to improve our products without prior notification. When required, request certified drawings.